

# RAPID LEVEL

## PATENTED LEVEL SWITCHES WITH UNIQUE CHARACTERISTICS

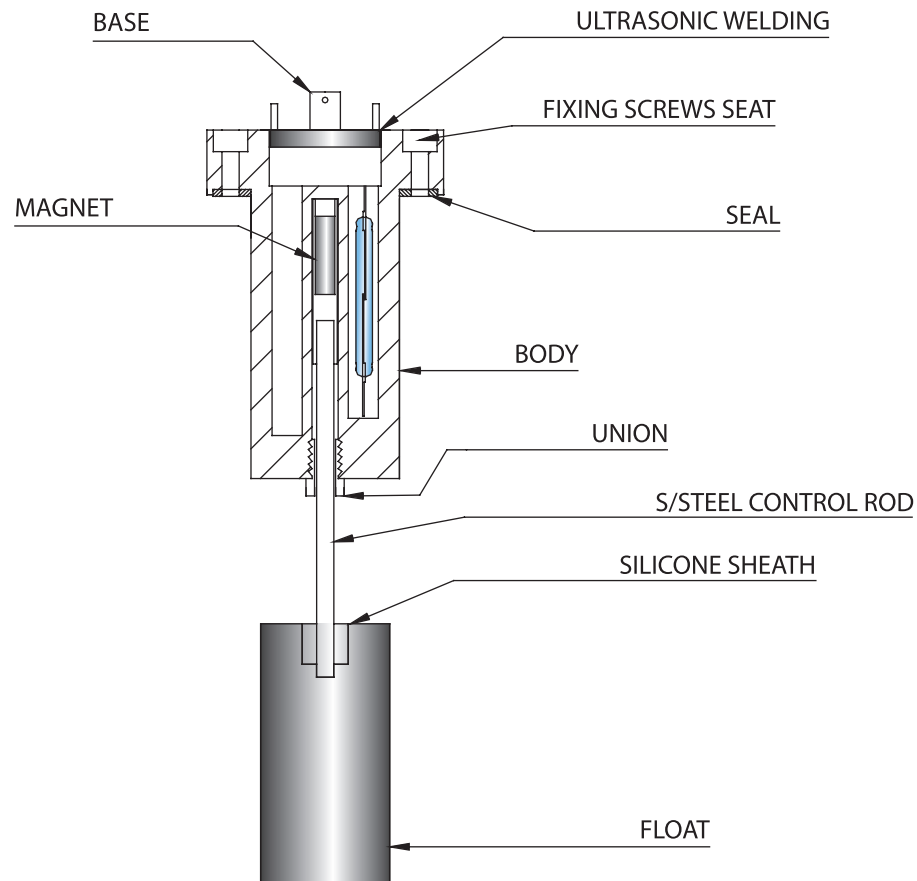

\* The required length can be obtained simply by cutting the steel rod, using an ordinary pipe cutter; or the switching point can be varied by using a float with through hole allowing the required liquid control point to be modified whenever necessary.

\* It can be used for dirty liquids, water, petroleum, cutting oils, and tolerates the presence of metal and ferrous particles, since the float does not hold a magnet and is integral with the rod.

\* One float can operate just one Reed (min. or max. level), or two Reeds (min. and empty and extra max. level) thus meeting the most complex needs.

\* Total safety since the electrical part is completely separate in the tank side and perfectly sealed with respect to the external side by means of ultrasonic welding.

\* The nylon-glass body is very strong and very resistant with respect to chemicals, and is ideal as an insulating container for the Reed contacts.

\* The Rapid Levels come standard with rods suitable for control of a max. measurement of 500 or 1000mm. To obtain specific measurements, refer to the table on the next page.

\* They can be ordered already arranged for the control of predetermined measurements.

## THROUGH FLOAT



On request the float can be supplied with through hole and therefore be positioned in the required position without having to cut the rod (which can therefore be as long as the height of the tank). If necessary, the liquid control point can be subsequently be modified as required by simply moving the float. Available on request with AISI 316 stop.

# RAPID LEVEL

## Rapid Level connection rod cutting table.

(NB : Carry out the cutting measurement with the rod in traction with respect to the body)

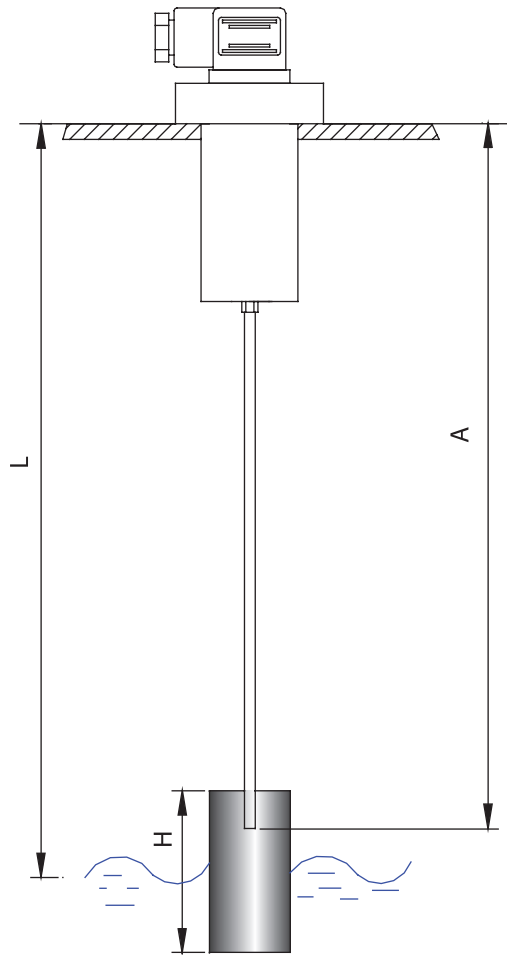

CONTROL VALUE L= (mm)	ROD CUTTING FOR MIN. LEVEL A= (mm)	CONTROL VALUE L1= (mm)	ROD CUTTING FOR MAX. LEVEL B= (mm)
90	116 H= 35		
100	116 H= 45		
110	116 H= 55		
120	116		
140	137		
160	158		
180	179	90	62 H1= 35
200	200	100	62 H1= 45
220	221	120	131
240	242	140	152
260	263	160	173
280	284	180	194
300	305	200	215
320	326	220	236
340	347	240	257
360	368	260	278
380	389	280	299
400	410	300	320
420	431	320	341
440	452	340	362
460	473	360	383
480	494	380	404
500	515	400	425
520	511	420	421
540	532	440	442
560	553	460	463
580	574	480	484
600	595	500	505
620	616	520	526
640	637	540	547
660	658	560	568
680	679	580	589
700	700	600	610
720	721	620	631
740	742	640	652
760	763	660	673
780	784	680	694
800	805	700	715
820	826	720	736
840	847	740	757
860	868	760	778
880	889	780	799
900	910	800	820
920	931	820	841
940	952	840	862
960	973	860	883
980	994	880	904
1000	1015	900	925

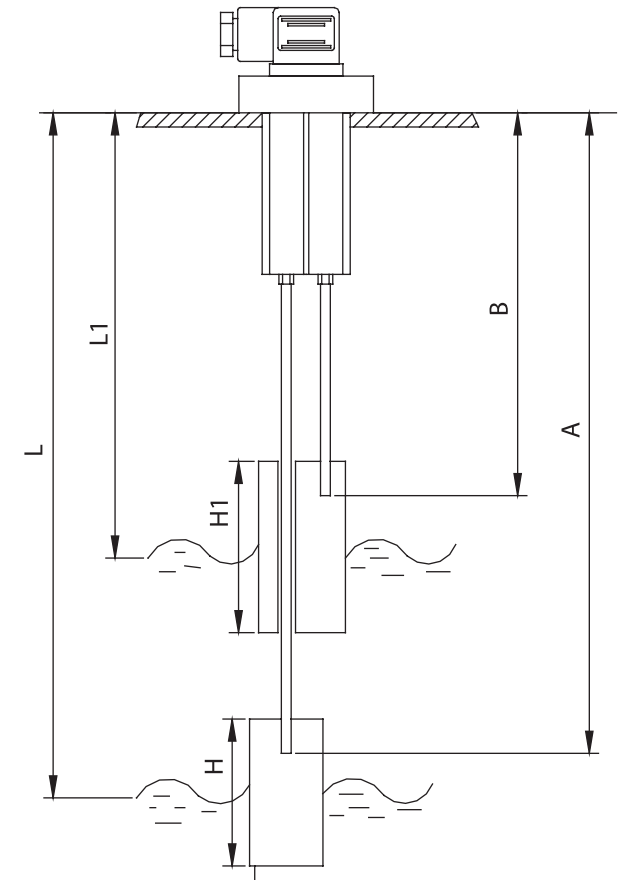

L-L1 = 100 mm  
A-B = 90 mm

H = 35 (L = 90 mm)  
H = 45 (L = 100 mm)  
H = 55 (L = 110 mm)  
H = 60 (L = 120 - 500 mm)  
H = 90 (L = 501 - 1000 mm)  
H1 = 35 (L1 = 90)  
H1 = 45 (L1 = 100)  
H1 = 70 (L1 = 120 - 1000 mm)

# RL/G1-F3

## RAPID LEVEL" TYPE LEVEL SWITCH WITH 1 FLOAT

# RL/G1-1"GAS

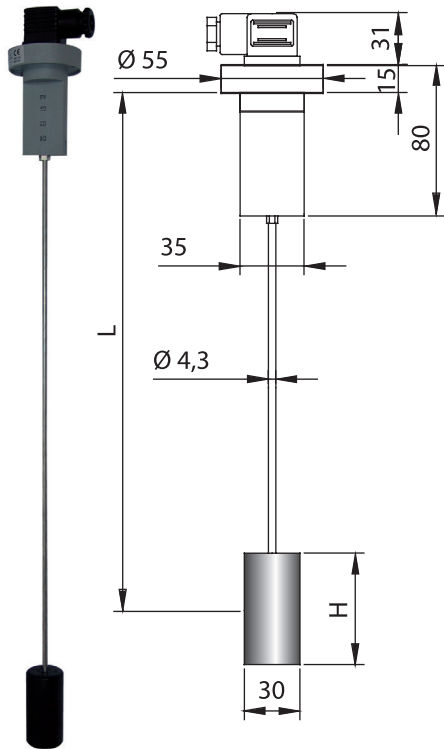

- ADVANTAGES OF THE RANGE**
- 1- These electromagnetic level gauges in Kits can be obtained in the required length "L" simply by cutting the control rod with an ordinary pipe cutter and press fitting the float in the cutting place (see table for cutting).
  - 2- The control rod can commute the signal of 1 or 2 Reeds in sequence (with single or exchange contact).
  - 3- The float does not hold magnets, therefore the Level can also be used in the presence of dirty liquids or ferrous particles.

### FIXING DIAGRAM

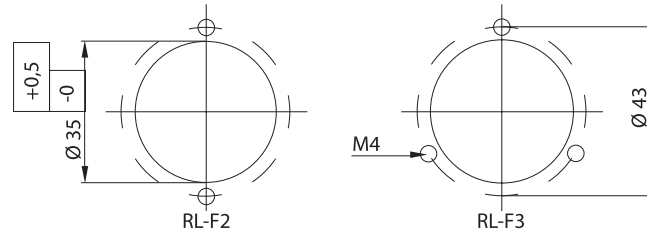

### CONNECTION:

Connector CE  
EN 175301-803-A IP65 PG.9/11

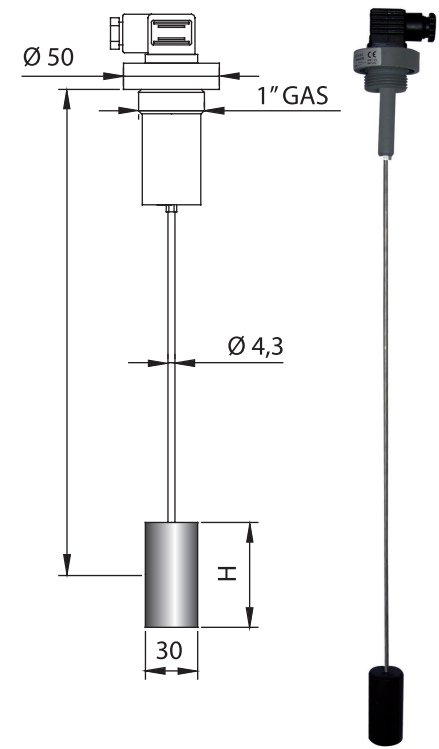

VERSION	CONNECTION	ELECTRICAL CONTACTS				REED	EXCHANGE REED	OPERATING TEMPERATURE -20 +80°C ON REQUEST 120°C	MAX. PRESSURE 10 Bar
RL / G1 - F3 (F2)	FLANGE 3 / 2 HOLES	S1= CLOSED IN ABSENCE OF LIQUID	S1A= CLOSED IN PRESENCE OF LIQUID	S2= EXCHANGE	S3= MIN.-EMPTY	S4= SPECIAL MIN.-EMPTY	3 A. 60W 60V.A. 230VDC 230 VAC		
RL / G1 - 1"GAS	1" GAS								
RL / G1 - 1"1/4 GAS	1" 1/4 GAS								
RL / G1 - 1"1/4 NPT	1" 1/4 NPT								