

VEM SERIE

The attraction and holding of the magnetic pieces are obtained feeding the winding inside the solenoid. When the power supply stops the electromagnet loses the piece.
When working with loads security norms must be respected.

Protection rate: IP65
Insulation class: B (130°C)
Standard voltage: 24 VDC
Standard duty cycle: ED100%
Other voltages, ED and sizes: Consult

Flying leads for every size.
Supply possibilities under demand:
- **With clamping screw** from the VEM25
- **With connector** from the VEM65.
The connector (1) has 4 possibilities of direction (4x90°) and it is possible to be incorporated to the same diodes of rectification for alternating current connection (AC).

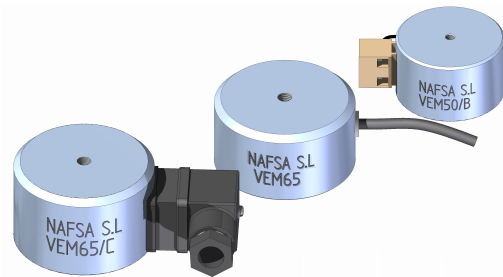
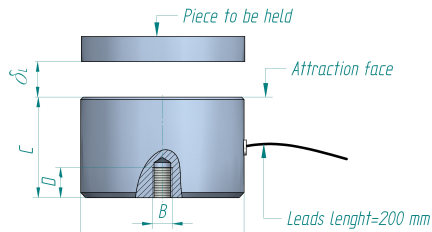

Table 1

TYPE	øA (-0,3)	B	C±0.1	D	E	F	Weight(Kg)
VEM 20	20	M-3	12	5	---	---	0.02
VEM 25	25	M-4	20	6	---	40	0.06
VEM 30	30	M-4	22	6	---	45	0.10
VEM 40	40	M-5	26	8	---	55	0.20
VEM 50	50	M-5	30	8	---	65	0.30
VEM 65	65	M-8	35	12	112	80	0.80
VEM 80	80	M-8	38	12	127	95	1.30
VEM 100	100	M-10	43	15	147	115	2.10
VEM 150	150	M-16	56	24	197	165	6.40

Flying leads: Ref: VEM (type)-V - ED%
Example: VEM 65-24Vdc- ED100%



Connector (C): Ref: VEM (type)/C-V-ED%
Example: VEM65/C-24Vdc ED100%
Connection:
see documentation that is enclosed with the material

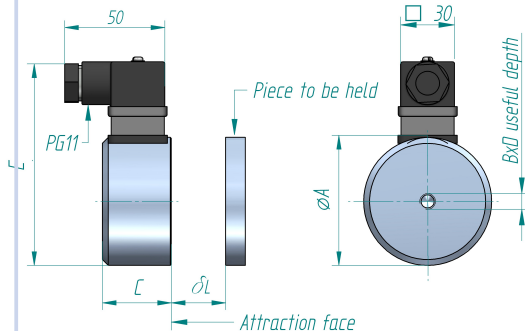

Clamping screw (B): Ref: VEM(type)/B-V-ED%
Example: VEM50/B-24Vdc-ED100%

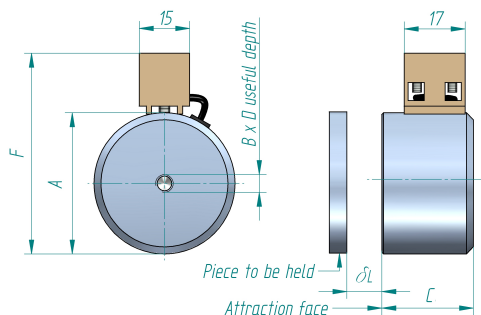

Important: the clamping screw does not have to exceed measure D

Table 2

TYPE	P at 20°C (W)	e (mm)	Air gap (mm) d_L					Magnetic Force Fm (N)
			0	0,1	0,2	0,5	1	
VEM20	1.6	1	14.5	3.8	1.6	0.3		
		3	27	5.7	2.6	0.35		
VEM25	3.2	1	27	19	12	3		
		3	114	47	20	3.5		
VEM30	4	1	37	24	18	6	1.5	
		3	170	80	40	9.5	1.6	
VEM40	5.6	1	38	30	24	13	4	
		3	300	203	133	27	4.5	
VEM50	6.5	1	40	32	30	20	15	
		3	320	235	185	65	16	
VEM65	10	1	45	40	35	25	15	
		3	310	290	250	148	40	
VEM80	15	1	65	42	40	30	20	
		3	430	360	325	230	90	
VEM100	20	1	70	50	45	35	25	
		3	530	440	426	335	225	
VEM150	40	1	1400	1200	1050	730	310	
		3	2600	2200	1700	880	330	
VEM150	40	3	700	580	550	480	390	
		6	1810	1650	1580	1400	1100	
VEM150	40	10	5800	4350	3910	3000	1850	
		18	7104	5760	4992	3840	2400	

e (mm): Thickness of the piece to hold

The table 2 gives for each type of holding magnet, the values of the force of maintenance (Fm) based on the air gap, measured in the following conditions:

- Direct current supply.
- Flat piece (3mm rugosity) in A°St37, thickness as shown in the table 2 and dimensions are similar or bigger than the attraction face.
- Room temperature 35°C.
- Coil working on its regime temperature.

At different conditions, the magnetic force(Fm) may decrease. The value of the magnetic remanence after the power supply stops is 5% of the holding force.

- .Earthing is recommended if the metallic parts are accessible.
- .Technical explanation: see documents 1.4 & 1.5
- .Under demand: any size, voltage, duty cycle etc can be manufactured.

! When lifting or handling heavy loads a minimum security margin of 3 must be respected, the weight of the load cannot exceed 33% of the magnetic force.